





MAGIC S3

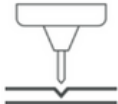

- 

Built-in Camera
- 

Supports Bluetooth Connection
- 

Diamond Engraving
- 

Fully Automatic
- 

Supports MagicEngrave™ Program

COMPACT ENGRAVING MACHINE MAGIC™-S3

MAGIC-S3 is a third-generation multipurpose desktop engraving machine that provides outstanding performance, excellent structural stability and modern design. It is the perfect engraving machine for engraving flat-type materials. It is designed with revolutionary features and functions for easy and fast engraving of materials with various forms and sizes.

It is easy and simple to use, and provides a wide range of functions and a powerful performance. It is especially built for multipurpose use, and is designed to make engraving and marking on a variety of products and materials like pet IDs, jewelries, accessories, cosmetic/perfume cases, and industrial name plates and parts, easy and fast.



MULTIPURPOSE SCRIBING MACHINE:

MAGIC-S3 is a multipurpose scribing machine perfectly used for engraving various items with various materials. It leaves a shiny, polished, high quality finish on items like pendants, pet tags, cosmetics, watches, military identification tags, Zippo lighters, machine nameplates, gift items, etc.

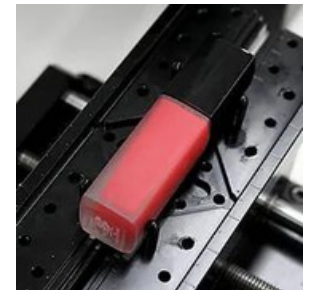
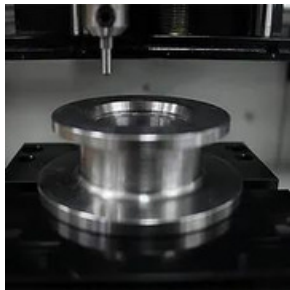

LASTING, PERMANENT AND POLISHED FINISH:

Benefits of Diamond Scribing

- Creates a deep, lasting, permanent mark
- Engraves on all metals, glasses and plastics
- Leaves a shiny, smooth, polished finish
- Easy, fast and quiet engraving
- Engraves on curved surfaces
- Safe to use scribing tools
- Simple and easy engraving operation for everyone

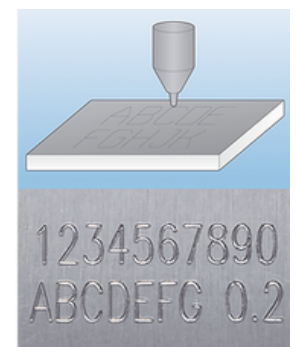

SUPPORT VARIOUS ENGRAVING TYPES:

Hatching Line

Creates horizontal or vertical line patterns at regular intervals

Diagonal/Cross Line

Creates diagonal or X-shaped cross line patterns at regular intervals

Contour Line

Creates line patterns by filling the border lines.

Outline

Creates border line patterns

Photo Marking

Creates photographs/images with dots



AUTO MEASUREMENT:

It has built-in height measurement sensors that automatically measure the height of the material to be engraved.

- The machine has auto measurement sensor that detects the height of the material.
- It sets the tool to its origin point automatically.
- It is designed for quick and easy use as users no longer need to adjust the tools manually.

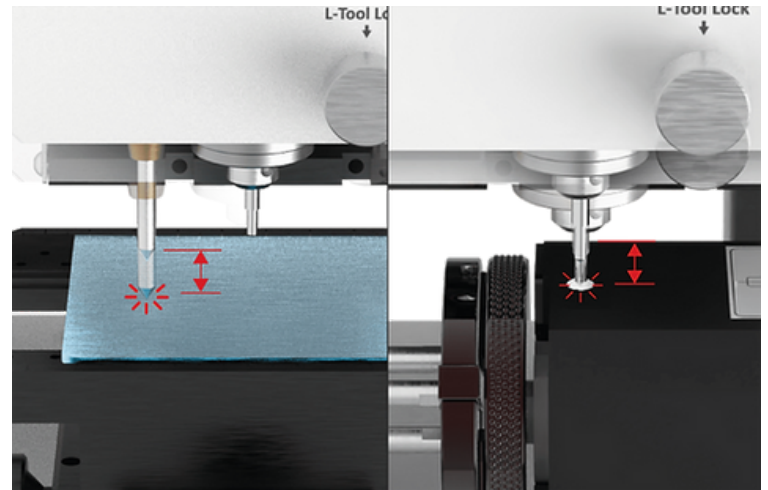

EASY CONTROL OF ENGRAVING POSITION:

It has a built-in camera that provides fast and easy control of the engraving position.

The machine enables intuitive operation through the use of an embedded camera that directly shows the engraving area on the material.

A laser pointer is also built in for users to easily locate and adjust the engraving position. It is designed for quick and easy engraving for all as no preparation is needed.

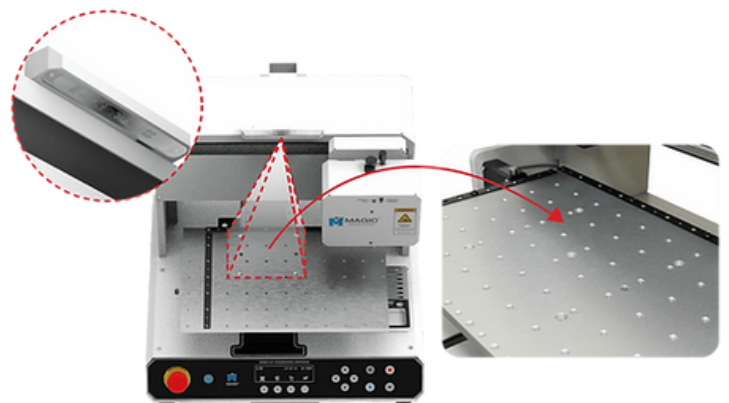

HIGH-SPEED MARKING:

It ensures high-speed marking on various materials. The machine is built for high-speed marking using a diamond tool. It ensures high quality marking on various materials at a high speed. Marking is made easy and quick as there are available clamps that firmly hold the materials during engraving process.



A WIDER WORK AREA:

It comes with a wider engraving area to enable size expansion of the materials to be engraved. The machine comes with a clamp to engrave in approx. 150mm x 130mm size. It has a wide inner space that makes it possible to firmly hold materials with sizes larger than the engraving area. Its open front and back allows users to deal with materials with longer sizes. Flexible sizing enables less restriction on the size of the material.



INNOVATIVE FUNCTIONS AND FEATURES:

MAGIC-S3 is designed with the latest, innovative functions and features. The third-generation multipurpose desktop engraving machine offers innovative functions for easy operation of the machine. The machine as a whole (including its parts and functions) has been re-designed following the new and latest technology. Great improvement in functionality, structural stability, performance, and design has been achieved to provide our customers with the most efficient and most advanced engraving machine that produces precise, lasting, high-quality engraving results.

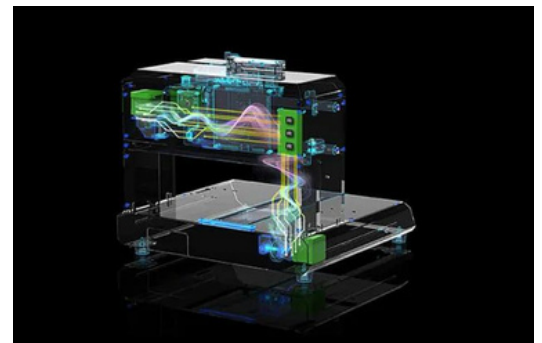

LATEST THIRD GENERATION MOTOR CONTROL SYSTEM:

The newly-developed third generation motor control system controls the machine with a resolution that is two times higher than that of its previous model, enabling high-quality, precise and accurate engraving and marking. The machine has a resolution that is twice as high as the previous models. The designs/images are expressed in a more detailed, precise manner, producing higher engraving and marking quality. The noise level of the machine is greatly reduced to create a favorable working environment.

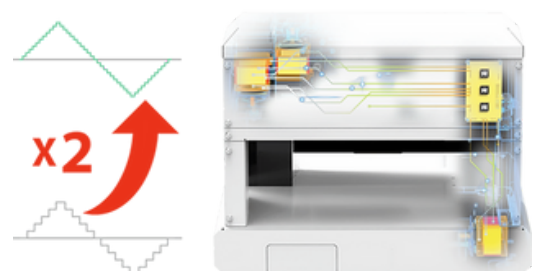

SMALL AND MODERN DESIGN:

The machine is small in size, and offers the benefits of less noise and easy installation.

TECHNICAL SPECIFICATIONS:

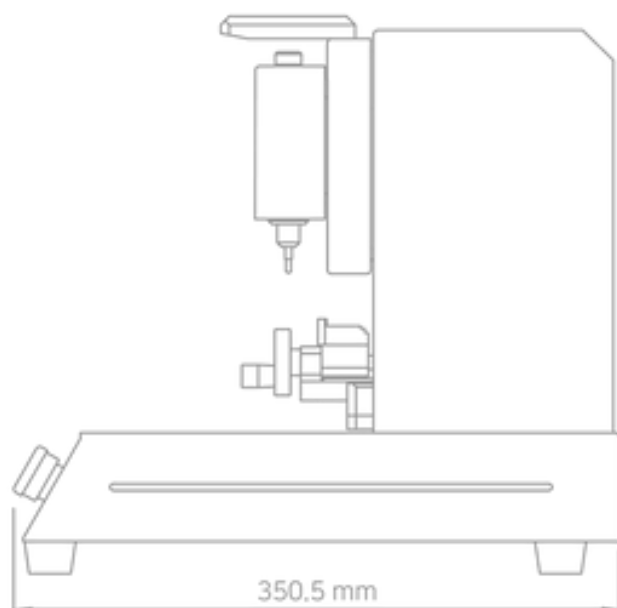
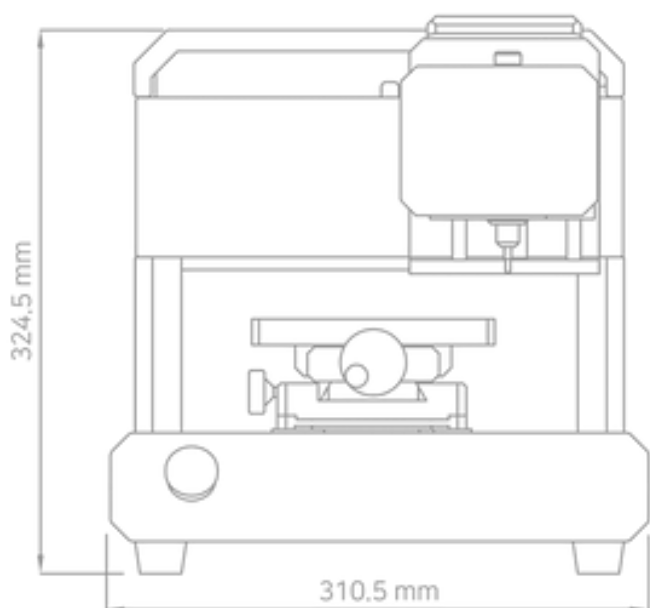

PRODOTTO	
Model	MAGIC™-S3
Size	310.5mm(W) x 350.5mm(D) x 324.5mm(H)
XYZ axis stroke	153mm(X) x 134mm(Y) x 38.5mm(Z)
Rotary outer diameter	17.5~80mm
Rotary inner diameter	14~75mm
Weight	19,60Kg
Voltage	AC 100~240V, 50Hz/60Hz
Power Consumption	24W
Flat engraving area	145mm x 120mm x 38.5mm
Max material height	40mm
Temperature	15~40°C
Humidity	10~90%

BLUETOOTH	Bluetooth BLE(Bluetooth 5.0) / Communication Range : Class 2(32.8ft) / Tx Output : MAX +4dBm / Frequency Band : 2.4 GHz
-----------	---



Via Roma II Novate Milanese (MI)
info@pelusi.com - Tel. +39 02 33240260

